

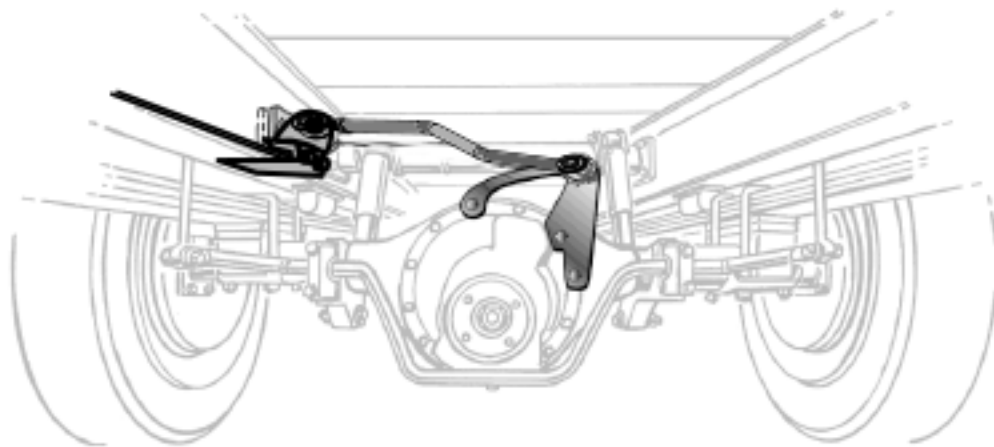

UTW22R Workhorse W20-W24 Chassis Rear Bar Installation Instructions

Each installation may vary due to chassis manufacturing options and variations in design. The rod assembly may be installed in several different combinations, such as either front or rear of the supplied brackets as well as using different bracket holes. The important thing is to maintain clearance between your trac bar and any chassis component (moving and stationary) such as exhaust, vehicle frame, differential, or any other item which might interfere with the operation of this product. Pictures and diagrams may not represent the best installation for every application.

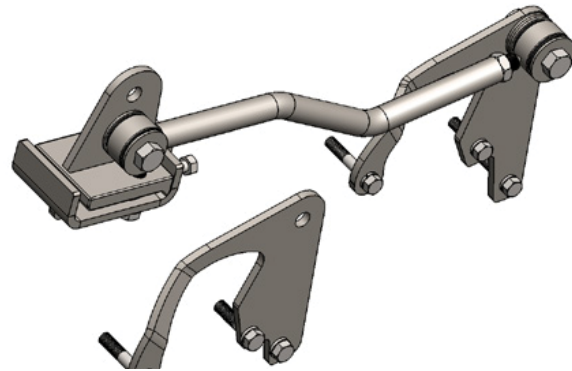

NOTICE

- Only a qualified mechanic using common automotive tools and following all safety standards should perform the installation of this product.
- If the vehicle is equipped with air bags be sure that nothing interferes with the deployment of them.
- Be sure to use a sufficient amount of Loctite® Red on all bolts before tightening. Tighten all bolts according to the torque charts provided or to the manufacturer's torque specifications on OEM parts. If no manufacturer specifications can be found then use the torque values provided.
- Dealer or installer, be certain the end-user receives these instruction sheets.

UTW22R

Workhorse W20-W24 Chassis Rear Bar

Installation Instructions

Note: There are two axle brackets in this kit. One fits the 110/115 (Metric) and the other fits the 135/150 (Standard) rear axle. Match the bracket to the bolt pattern of your axle and discard the bracket that does not fit.

Tools Required

Torque Wrench
 Loctite® RED
 3/4" Socket
 3/4" Wrench
 7/8" Socket
 1-1/16" Socket
 1-1/8" Wrench
 22MM Socket
 6" Drive Extension

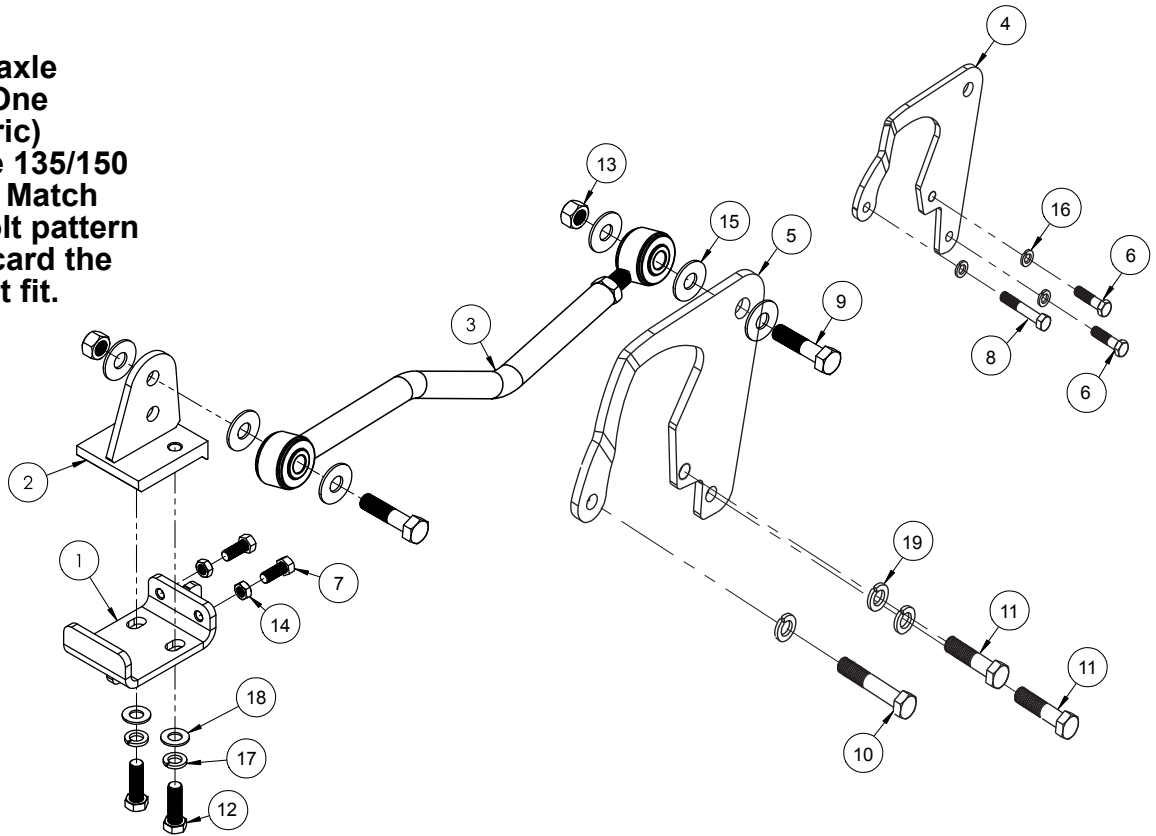

Item No.	Part Number	Description	Qty.
1.....	61-6745.....	Frame Bracket Weldment.....	1
2.....	61-6746.....	Nut Plate Frame Bracket Weldment.....	1
3.....	62-3633.....	Rod Assembly.....	1
4.....	101-7142.....	135/150 Rear End Spicer Bracket.....	1
5.....	101-7143.....	110/115 Rear End Spicer Bracket.....	1
6.....	201-0283.....	1/2"-13 x 2" Hex Head Bolt, Grade 8, ZP.....	2
7.....	201-0308.....	1/2"-20 x 1-1/4" Hex Head Bolt, Grade 8, ZP.....	2
8.....	201-0490.....	1/2"-13 x 3" Hex Head Bolt, Grade 8, ZP.....	1
9.....	201-0632.....	3/4"-16 x 3.5" Hex Head Bolt, Grade 5, ZP.....	2
10.....	201-0812.....	14MM-2MM x 80MM Hex Head Bolt, 10.9 HCS.....	1
11.....	201-0813.....	14MM-2MM x 50MM Hex Head Bolt, 10.9 HCS.....	2
12.....	201-0912.....	5/8"-18 x 2" Hex Head Bolt, Grade 8, ZP.....	2
13.....	202-0168.....	3/4"-16 Top Lock Nut, ZP.....	2
14.....	202-0184.....	1/2"-20 Jam Hex Nut.....	2
15.....	203-0007.....	3/4" Flat Washer, ZP.....	6
16.....	203-0012.....	1/2" Lock Washer, ZP.....	3
17.....	203-0013.....	5/8" Lock Washer, ZP.....	2
18.....	203-0106.....	5/8" SAE Flat Washer, ZP.....	2
19.....	203-0131.....	14MM Lock Washer, ZP.....	3
20.....	190-0155 (not shown).....	10"-5/8" Loom.....	1
21.....	290-0275 (not shown).....	7.6" 50LB Cable Tie.....	2
22.....	150-433 (not shown).....	.5ml Capsul 262 Threadlock.....	1

Important:

Use only genuine factory replacement parts on your trac bar. Do **NOT** substitute homemade or non-typical parts. If a bolt is lost or in need of replacement, for your safety and the preservation of your trac bar, be sure to use a replacement bolt of the same grade (In most cases it will be Grade 5, please reference the parts list above).

UTW22R
Workhorse W20-W24 Chassis Rear Bar
Installation Instructions

Installation Instructions

1. Position the vehicle on a level surface with the front wheels straight ahead and sitting at normal ride height. Set the brake and chock all the wheels.
2. Hold the axle brackets up to the rear end to locate the three (3) OEM bolts that line up to one of the brackets. Remove the OEM bolts and install the bracket to the rear end with the supplied bolts and lock washers. If the rear end had flat washers, reuse the washers in between the bracket and the rear end housing. Tighten all bolts.
3. Position the frame bracket onto the passenger side frame rail and loosely secure it with the nut plate frame bracket and the 5/8"-18 x 2" bolts with 5/8" lock and flat washers. Loosely install the two (2) 1/2"-20 x 1-1/4" bolts with the 1/2"-20 jam nuts into the frame bracket. The bracket needs to be loose enough on the frame rail to move back & fourth to line up with the axle bracket.
4. Install the rod assembly onto the front of the axle bracket with one (1) 3/4"-16 x 3" bolt, two (2) 3/4" flat washers and a 3/4" lock nut. Be sure the flat washers are on either side of the urethane bushing. Position the frame bracket so it is straight with the axle bracket and rod assembly. Adjust the length of the rod assembly until you are able to pass a bolt thru both the rod assembly and frame bracket. Install a 3/4" bolt, two (2) flat washers and a 3/4" lock nut into the rod assembly and frame bracket. Leave all bolts finger tight for now.
5. Once the frame bracket is straight with the rod assembly and axle bracket, alternately tighten down the 5/8" bolts on the frame bracket and torque to specifications. Then torque the 1/2"-20 x 1-1/4" bolts to the frame and tighten the jam nuts.
6. Torque the 3/4" bolts in the rod assembly to specifications. Inspect for any wiring or hoses that may rub against the brackets and secure in a safe position with the loom and/or cable ties provided.

Item #	Torque
6/8: Bolt 1/2"-13 x 2"/3"	120 #
7: Bolt 1/2"-20 x 1.25"	45 #
9: Bolt 3/4"-16 x 3"	150 #
10/11: Bolt 14-2x50/80mm	150 #
12: Bolt 5/8"-18 x 2"	80 #
14: Jam Nut 1/2"-20	35 #