



The Towing Experts

LP-BK01

Lube Pump Base Kit

**General Information
and
Motorcoach and Towed Vehicle
Wiring Instructions**



**INSTALLER: GIVE THESE INSTRUCTIONS TO THE END
USER AFTER INSTALLATION FOR THEIR FUTURE
REFERENCE.**

Table of Contents

Limited Warranty	pg 3-4
Warranty Registration	pg 5-6
Overview	pg 7
Towed Vehicle Electrical Wiring	pg 8
Electrical Schematic (Towed Vehicle)	pg 9
Installation of Taillight Diverters	pg 11
Installation of Conductor Cable	pg 14
Motor Home Electrical Installation	pg 15
Installation of Electrical Monitor	pg 15
Installation of Harness Assembly	pg 16
Electrical Schematic (Motor Coach)	pg 18
Testing The Installation	pg 19
Towing Checklist	pg 20
Troubleshooting	pg 20-21
Three Wire Taillight system Instructions	pg 23-25

Limited Warranty – January 1, 2012

I. LIMITED WARRANTY ON AUTOMATIC TRANSMISSION:

REMCO – RECREATIONAL EQUIPMENT MANUFACTURING CORPORATION warrants under the terms stated here that there will be no abnormal wear or damage to the automatic transmission resulting from the use of the **REMCO LUBE-PUMP**.

- a. This warranty is for a period of one (1) year from the original date of installation.
- b. This transmission warranty is for 10,000 miles or 1 year, which ever comes first. This transmission warranty ceases under any condition when the vehicle's mileage exceeds 40,000 miles.
- c. This warranty is valid only on those vehicles that have been approved by **REMCO** in writing for the installation of the **LUBE PUMP**.
- d. The **LUBE-PUMP** system must be installed and operated in accordance with **REMCO'S** installation and operation procedures.
- e. This warranty applies only to the original user/purchaser of the **LUBE-PUMP**.

II. LIMITED WARRANTY ON LUBE-PUMP AND COMPONENT PARTS:

REMCO warrants their products to the original purchaser for a period of one (1) year from the original date of installation.

REMCO WARRANTS THEIR PRODUCTS AGAINST DEFECTIVE MATERIALS AND WORKMANSHIP. THIS WARRANTY IS VOID IF THE PRODUCT IS DAMAGED BY ACCIDENT OR UNREASONABLE USE, NEGLIGENCE, IMPROPER SERVICE, OR OTHER CAUSES NOT ARISING OUT OF DEFECTS IN MATERIAL OR WORKMANSHIP. THIS WARRANTY IS NOT SUBJECT TO MISUSE, ABUSE, ASSIGN, OR TRANSFER.

REMCO will either repair or replace during the above one (1) year all defective parts. Defective parts must be delivered or shipped prepaid and insured to **REMCO**. Parts must be accompanied with proof of date and place of purchase. THE EXCLUSIVE REMEDY UNDER ANY AND ALL WARRANTIES AND GUARANTEES EXPRESSED OR IMPLIED IS LIMITED TO THE REPAIR AND/OR REPLACEMENT AS PROVIDED HEREIN. IN NO EVENT SHALL **REMCO** BE LIABLE FOR ANY INDIRECT, INCIDENTAL, SPECIAL, EXEMPLARY, PUNITIVE, OR CONSEQUENTIAL DAMAGES OF ANY NATURE WHATSOEVER, INCLUDING, WITHOUT LIMITATION, ANY SUCH DAMAGES FOR LOSS OF PROFITS, LOSS OR DELAY OR EQUIPMENT USE OR OTHER INTANGIBLE DAMAGES.

III. INSTALLATION REQUIREMENTS AND WARRANTY REGISTRATION CARD:

The **REMCO LUBE-PUMP** must be installed in accordance with installation instructions provided by **REMCO**. A warranty registration card, included with the installation instructions, must be fully completed, signed and returned to **REMCO**. The purchaser is responsible to return the warranty registration card at the time of the installation to validate the warranty.

IV. WARRANTY SERVICE AND REPAIR:

- a. If the **LUBE-PUMP** system or the automatic transmission becomes unserviceable during the warranty period the purchaser should first, if possible, contact the installing dealer or mechanic for a determination of the problem. If the dealer or mechanic cannot be contacted then call **REMCO** at 1-800-228-2481 or 1-763-253-4740.
- b. Either the dealer or the purchaser must contact **REMCO** to obtain authorization before any warranty repair is performed.
- c. **REMCO** will pay no repair claims unless the **REMCO** personnel in Plymouth, Minnesota authorize the repair.
- d. The purchaser will be responsible for arranging to obtain the labor to repair the **LUBE-PUMP** system and/or transmission.
- e. Material evidence of component part failures resulting from the use of the **LUBE-PUMP** must be delivered to **REMCO** in Alexandria Minnesota, or an appointed representative accompanied with Cooler Flow Test data and basic Line Pressure data.

- f. Certification of the origination of all returned parts (i.e.: vehicle VIN, vehicle mileage, date of removal, list of parts by number) must accompany delivery to **REMCO** or an appointed representative.
- V. After **REMCO** has inspected the material evidence indicating the failure resulting from the use of the **LUBE-PUMP**, **REMCO** will reimburse labor and material cost to the purchaser.
- VI. **LIMITATIONS:** The warranties stated above are not unconditional guarantees against all hazards and failures. **THE ABOVE WARRANTIES DO NOT COVER:**

- a. Any damage to parts caused by acts of nature or accidents of any kind.
- b. Abnormal usage such as high speed racing, heavy trailer towing or other abuse and neglect.
- c. Failure of parts or equipment not supplied by **REMCO**.
- d. Leaking gaskets or hoses.
- e. Failure due to use of improper or inadequate amounts of transmission and coolant fluids.
- f. Failure by third parties to properly install the **LUBE-PUMP** system. (This does not apply to systems installed by **REMCO**.)
- g. Unauthorized modifications to the **LUBE-PUMP** system.
- h. Towing of the vehicle in excess of the legal posted speed limits.
- i. Failure of the operator to follow operating procedures as printed in the installation Manual and Towing Checklist.
- j. Costs incurred by the purchaser for telephone, shipping, substitute transportation, or loss of time, earnings, profits or any other consequential damages. These warranties are valid only under the conditions and limitations herein stated to the original purchaser and are not transferable. Repairs or replacements during the warranty period do not extend the life of the warranties.

VI. **REMCO** reserves the right to make changes and/or improvements in the product at any time without notice. **REMCO** shall not be obligated to incorporate such changes and/or improvements in products previously sold, nor be obligated to replace previously sold products with products incorporating such changes and improvements.

VII. No person, agent, distributor, dealer, or company is authorized to change, modify, or extend the terms of these warranties in any manner whatsoever. Notwithstanding any maximum limitation periods set forth under any applicable law or statute, the time within which any action must be commenced to enforce any obligation of **REMCO** arising under the warranty or under any applicable statute or law is hereby limited to the duration of the warranty set forth above, commencing from the date of purchase.

ALL WARRANTIES IMPLIED BY STATE LAW, INCLUDING THE IMPLIED WARRANTIES OF MECHANICABILITY AND FITNESS FOR A PARTICULAR PURPOSE, ARE EXPRESSLY LIMITED TO THE DURATION OF THE LIMITED WARRANTIES SET FORTH ABOVE. WITH THE EXCEPTION OF ANY WARRANTIES IMPLIED BY STATE LAW AS HEREBY LIMITED, THE FOREGOING WARRANTY IS EXCLUSIVE AND IN LIEU OF ALL OTHER WARRANTIES, GUARANTEES, AGREEMENTS AND SIMILAR OBLIGATIONS OF MANUFACTURER OR SELLER WITH RESPECT TO THE REPAIR OR REPLACEMENT OF ANY PRODUCTS OR PARTS.

VIII. This warranty gives you specific legal rights and you may also have other rights which may vary from state to state. Some states do not allow limitation on how long an implied warranty lasts, when an action may be brought, or the exclusion or limitation of implied warranties or incidental or consequential damages, so the above provisions may not apply to you.

IX. In plain language, how does it all work? We sell you a quality product and then we stand behind it. If you have problems with our products we want to take care of it. Satisfied customers say good things to others and this is our objective. Call us toll free at 1-800-228-2481 or 1-763-253-4740 if we can be of any help or service.

X. The foregoing warranty and the sale of the **REMCO** products to you shall be governed by and construed in accordance with the laws of the State of Minnesota (U.S.A.), without regard to principles or conflicts of laws, and you irrevocably consent to and submit to the exclusive jurisdiction and venue of the state and federal courts in Plymouth, Minnesota, for the purpose of all legal proceedings arising out of or relating to the foregoing warranty and the sale of the **REMCO** products to you.



The Towing Experts

WARRANTY REGISTRATION

ALL INFORMATION MUST BE COMPLETE TO REGISTER YOUR WARRANTY

ALL INFORMATION IS FOR TOWED VEHICLE

Customer's Name: _____

Permanent Address: _____

City: _____ State: _____ Zip: _____

Phone Home: _____ Cell: _____

Towed Vehicle Year: _____ Make: _____ Model: _____

Identification No. (VIN): _____

Odometer Mileage When Installed: _____

Kit Installed _____ (ie: LP-BK01-018)

Date Installed: _____

Installed By: _____ Mechanic: _____

Address: _____ City: _____

State: _____ Zip: _____

BY SIGNING THIS REGISTRATION THE UNDERSIGNED ACKNOWLEDGES THAT THE WARRANTY TERMS, CONDITIONS AND LIMITATION SET OUT IN THE REMCO LIMITED WARRANTY ATTACHED HERETO AND ON PAGES 3 AND 4 OF THE REMCO GENERAL INFORMATION MANUAL ARE PART OF THE AGREEMENT BETWEEN THE PARTIES AND INCORPORATED HERIN BY REFERENCE. THE UNDERSIGNED ACKNOWLEDGES THAT BY SIGNING THIS REGISTRATION, THEY HAVE READ THE LIMITED WARRANTY, UNDERSTAND THE PROCEDURES AND TERMS THEREIN, AND ACCEPT THOSE TERMS.

Signed: _____ Date: _____

Please send back within 30 days of installation via: Mail, Fax, or Email to:

Remco Industries
4605 County Road 82 SE
Alexandria, MN 56308
1-800-228-2481 * 763-253-4743
Fax: 763-253-4741

warranty@remcoindustries.com

Name: _____

place stamp here

Address: _____

City,St,Zip:: _____

Remco Industries
4605 County Road 82 SE
Alexandria, MN 56308

WARRANTEE REGISTRATION

-----fold here-----

-----fold here-----

THE REMCO LUBE PUMP

REMCO's Lube-Pump provides a proven, safe and reliable method of towing select front wheel drive, rear wheel drive, four wheel drive, and all wheel drive automatic transmission vehicles behind your motor home with all four wheels on the ground. **REMCO's** Lube Pump Systems are Transmission dependent. Please make sure your vehicle is equipped with a Transmission that has been approved by **REMCO** for use with the Lube Pump. **REMCO** provides the pump system, tail light system and all electrical connections. **REMCO** can provide the tow bar and brackets for most vehicles.

A durable 1/8 horsepower self-priming pump provides effective lubrication of the towed vehicle's transmission while being towed. The pump is activated or deactivated when the electrical monitor is switched on or off and the motor home's ignition is in the **ON** position.

The motor home is connected to the towed vehicle with a single cable, which operates the pump, monitor, and the towed vehicle's taillights. When the cable is connected, the taillights, brake lights, and turn signals of the towed vehicle are automatically controlled from the motor home. When the cable is disconnected, the taillights, turn signals, and brake lights of the towed vehicle operate normally.

In addition, a fail-safe electronic alarm system is built into the monitor, giving you a visual and audible signal if for any reason your **LUBE-PUMP** is not delivering adequate lubrication. One more unique feature of the alarm system is when you plug your towed vehicle into your motor home, with the motor home ignition **ON**, the red light and alarm will operate until the monitor switch is turned **ON** and the pump begins operating so you don't drive down the road with the pump off and in the process ruin your transmission.

The **REMCO LUBE-PUMP** is designed to give you maximum convenience and safety when the system is properly installed. Please follow the installation instructions very carefully. Any questions or problems, please call **REMCO** at 1-800-228-2481.

**** WARNING ****

SAFETY FIRST – Use caution when working on a vehicle. Do not get hands into fan belts or other moving parts. Do not get under any vehicle that is supported by a jack only. Be sure vehicle is properly blocked and supported by jack stands before getting under it.

CAUTION – An improperly installed **LUBE-PUMP** system can cause failure of the towed vehicle's transmission and other system components. All motor home electrical power used for the monitor, pump, or towed vehicle's taillights must be 12 volts DC. Bus type chassis may have 24-volt DC electrical system and will need to be converted to 12 volts DC. A 12-volt source must be on the motor home to run the monitor, pump, and converter.

IMPORTANT!

INSTALL THE LUBE PUMP AND ALL NECESSARY PLUMBING ON TOWED VEHICLE FIRST BEFORE INSTALLING WIRING ON MOTOR COACH AND TOWED VEHICLE.

SEE

LUBE PUMP AND PLUMBING INSTALLATION INSTRUCTIONS
THESE INSTRUCTIONS COME WITH THE SPECIFIC HARDWARE PACK FOR YOUR TRANSMISSION. IF YOU DO NOT HAVE THIS HARDWARE PACK, DO NOT CONTINUE WITH THE INSTALLATION! CALL REMCO IMMEDIATELY!

TOWED VEHICLE ELECTRICAL WIRING:

The **REMCO LUBE PUMP KIT** includes all wiring and electrical hardware needed to connect the electronic monitor on the motor home dash panel and the **LUBE PUMP** in the towed vehicle. The kit provides for the automatic control of the taillights and turn signals of the towed vehicle.

NOTE 1: Some motor homes are equipped with separate turn signals and brake lights for which a special converter (the PL-100, not included in the **LUBE PUMP KIT**) will be required. (see pg 15)

Check the parts in the kit, against the parts list below, to familiarize yourself with each item and to make sure none are missing.

For proper installation it is necessary for you to have available the following tools which are not provided in the kit:

• 12 volt DC continuity tester
• Small wire cutter, wire stripper, wire terminal crimper
• Electrical tape
• Screw driver
• Electric drill, #7 drill bit, and 3/8" nut driver bit

The following wiring parts are to be installed in the Motorhome.

MOTOR COACH PARTS		
Part #	Description	Quantity
10010005	Motorhome Harness w/6-conductor socket & bracket	1
10010016	Electrical Monitor	1
11010030	LP-Generic Hardware Pack	1

The following wiring parts are to be installed in the towed vehicle

Part #	Description	Quantity
10010009	Towed Vehicle Harness w/6-cond. socket & bracket	1
10010019	Diverter Pack Assy (4)	1
10040007	Coiled Cable Assembly w/2 6-conductor Plugs	1
	General Information Instruction Book	

TOWED VEHICLE

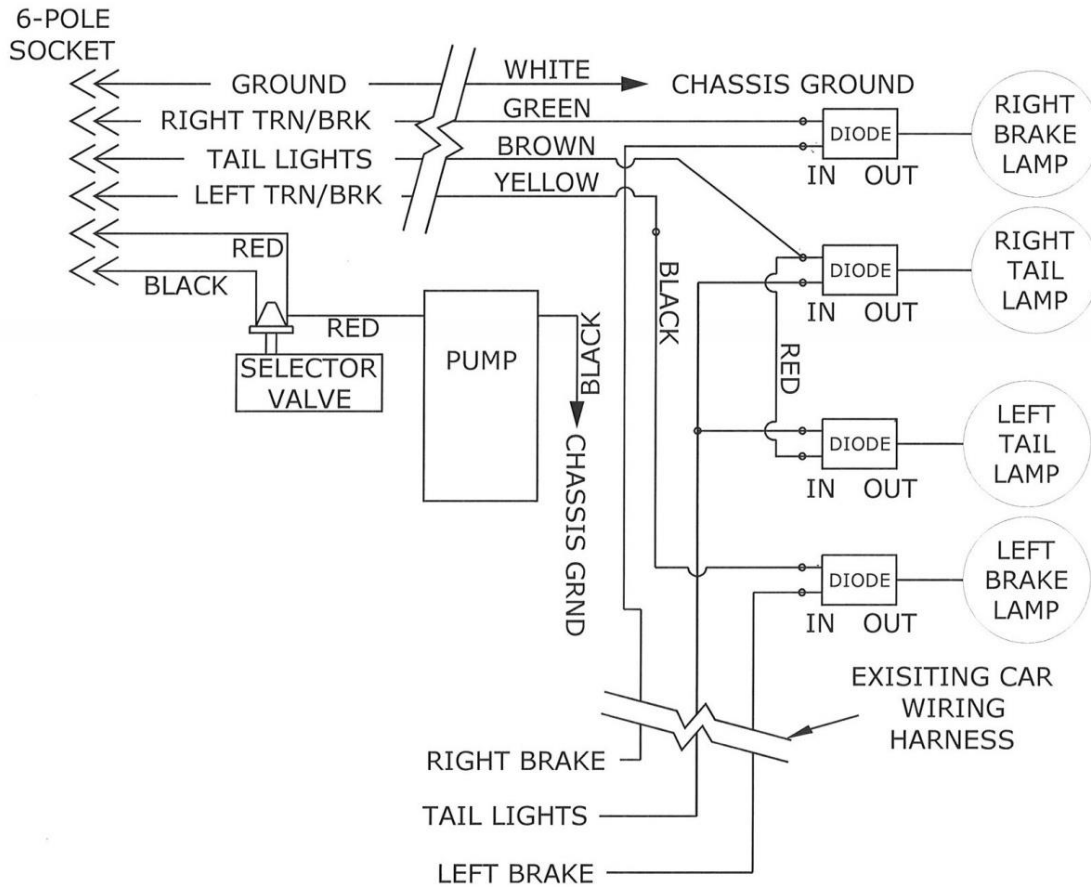

SOCKET & PLUG - DETAIL

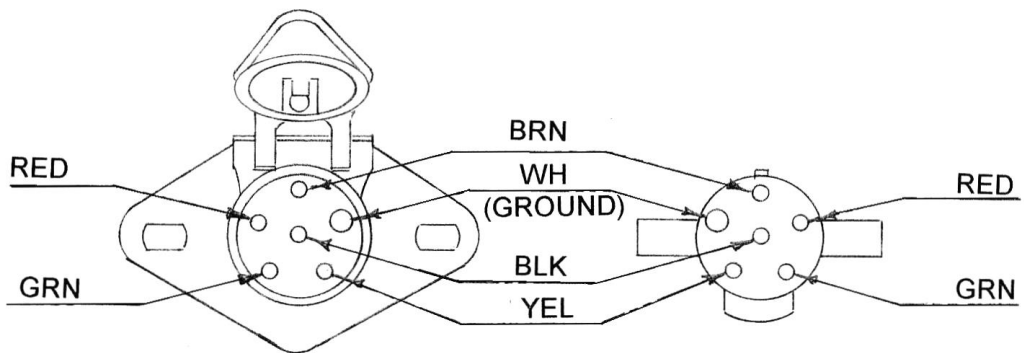

MOTORHOME & CAR SOCKETS
(Same on both vehicles)

CONNECTOR CABLE PLUGS
(Same on both ends)

TOWED VEHICLE ELECTRICAL INSTALLATION:

Note 1: Towed Vehicle Electrical Installation should be conducted after installer has properly plumbed Remco Lube Pump and other Transmission related components (i.e. Port Fitting, Drain Plug, and Selector Valve). Valve with Pressure Switch on it must be properly plumbed before electrical connections can be made.

NOTE 2: Carefully study the **electrical schematic diagram**, on page 10, to become acquainted with the overall wiring plan and the circuitry.

NOTE 3: The coiled cable should rest on the tow bar if the sockets on both vehicles are either opposite of each other or the sockets are mounted in the middle of both vehicles to allow the cable to rest on the tow bar. Whichever way is used, the result will be the same; to keep the cable from dragging on the ground. When the cable is not in use, it should be disconnected from both vehicles and stored. The cable will keep its coiled memory and last for many trips down the road.

Step 1. Two 1/4" x 3/4" self-tapping metal screws are provided to mount the socket bracket. Make sure the socket is located high enough to provide curb and roadway clearance.

Step 2. Connect the 5 ft. length of white wire from the socket to a suitable chassis ground at the front of the vehicle, not the frame. Normally, an existing screw or bolt can be loosened to make this connection near the socket mounting. Trim the white wire to a suitable length, strip back the insulation, and crimp a spade terminal to the end for fastening to the screw or bolt. Make certain the terminal is crimped securely. Moderately pull on the terminal to check. Check all terminals similarly when installed.

Step 3. Run the 5 ft. long 2-conductor cable (red & black) from the socket, to the pressure switch, which is integral part of the pressure switch assembly you have already installed. Cut the 2-conductor cable to proper length, separate the wires back approximately 3 inches and crimp a 1/4" female terminal onto each wire. Connect one wire to each of the two blade connections on the pressure switch. **Since polarity is not critical, either wire can be connected to either terminal.**

*****Note*****In some installations a Selector Valve will not be used, but another valve known as a Pressure Switch assembly will be used instead and will be working in conjunction with a check valve. If your Transmission requires the use of one of these assemblies, then connect the red and black wires to the Pressure Switch Assembly.

Step 4. Attach one end of the 5 ft. long red wire provided in the kit to the red wire of the 2-conductor cable at the pressure switch using one of the self-stripping wiretap connectors provided.

Step 5. Take the other end of the 5 ft. long red wire and route it to the lube pump then, cut to length. Strip back the insulation on red wire and crimp on the 1/4" male terminal (provided). This will provide a ready connection with the female terminal already installed on the red wire extending from the pump, which you have already installed. Make sure the wires are kept clear of all moving parts and are not touching parts, which become hot when the vehicle is driven. It is usually best to follow the same paths as existing wiring under the vehicle's hood.

Step 6. Connect the black wire extending from the pump to a nearby ground. Either loosen an existing bolt or drill a hole and fasten the wire using one of the 1/4" x 3/4" self-tapping metal screws provided in the kit.

• **INSTALLATION OF TAILLIGHT DIVERTERS**

NOTE: Prior to installation, determine which taillight wiring system you have on the towed vehicle: a 3- or 4-wire system. A 3-wire system has combined turn signals and brake lights (red turn signals). A 4-wire system has separate turn signals and brake lights (amber turn signals). If you have a 3 wire system, please refer to the Three Wire Tail Light System Wiring Supplement - pg 23.

INSTALLATION OF TAILLIGHT DIVERTERS FOR 4-WIRE SYSTEMS

NOTE 1: This system uses all 4 diverters supplied in this kit.

NOTE 2: With some vehicles, the taillight assembly must be removed to gain access to the taillight wires.

NOTE 3: The amber turn signals are not used, instead, the brake lights become the turn signals and brake lights for towing only.

NOTE 4: Refer to **electrical schematic, page 10**, for steps listed below.

- Step 1. Start at the driver side taillight assembly. Access the wires for the taillight assembly.
- Step 2. Turn **ON** the taillights.
- Step 3. Ground the continuity tester to a suitable ground.
- Step 4. Probe each wire to locate a “HOT” wire. Turn **OFF** and **ON** the taillight switch to verify the correct wire. Label the wire “LEFT TAILLIGHT”. Follow the same procedure for the passenger side taillight assembly, but label the wire “RIGHT TAILLIGHT”. Turn **OFF** the taillights.
- Step 5. Have an assistant depress the brake pedal. Start at the driver side taillight assembly. Probe each wire for a “HOT” wire. Have the assistant depress the brake pedal **ON** and **OFF** to verify the correct wire. Label the wire “LEFT TURN/BRAKE”. For the passenger side taillight assembly, follow the same procedure, but label the wire “RIGHT TURN/BRAKE”.
- Step 6. Refer to **electrical schematic, page 10**, return to the drivers side taillight assembly. Turn **ON** the taillights; locate the wire labeled “LEFT TAILLIGHT”. Cut the wire. Confirm that the taillight goes **OUT**. Turn **OFF** taillights. Strip each wire ¼” crimp a ¼” red female terminal onto each wire. Connect the wire that goes to the taillight bulb to the “OUT” terminal of the diverter. Connect the remaining wire to either “IN” terminal of the diverter. For the passenger side taillight assembly, locate the wire labeled “RIGHT TAILLIGHT” and follow the same procedure as above.
- Step 7. Return to the driver side taillight assembly. Have the assistant depress the brake pedal. Locate the wire labeled “LEFT TURN/BRAKE”. Cut the wire. Confirm that the brake light goes **OUT**. Strip each wire ¼”. Crimp a ¼” red female terminal onto each wire. Connect the wire that goes to the brake light bulb to the “OUT” terminal of the diverter. Connect the remaining wire to either “IN” terminal of the diverter. For the passenger side taillight assembly, locate the wire labeled “RIGHT TURN/BRAKE” and follow the same procedure as above.

INSTALLATION OF CONDUCTOR CABLE

NOTE 1: Refer to **electrical schematic, page 10** for the following steps.

NOTE 2: For driver and passenger side conductor cable installation, two separate wires will be routed between the driver side and passenger side taillight assembly, either inside the trunk area or underneath the vehicle.

Step 1. Route the conductor cable from the socket underneath the vehicle along the passenger side to the passenger side taillight assembly.

NOTE 3: At the taillights, eight feet of two conductor will be needed to run from driver side to passenger side (not supplied).

Step 2. Separate the conductor cable wires sufficiently to attach the diverters. Strip each wire ¼". Crimp a ¼" blue female terminal onto the green conductor wire. Connect the green conductor wire to the remaining "IN" terminal of the "RIGHT TURN/BRAKE" diverter.

Step 3. Using a single, 10ga, ¼" yellow female terminal, crimp together the red wire from the two conductor and the brown wire from the three conductor. Connect it to the remaining "IN" terminal of the "RIGHT TAILLIGHT" diverter.

Step 4. Using a butt connector, crimp one side to the black wire of the two conductor and the other side to the yellow wire of the three conductor. Extend the two conductor to the driver side taillight assembly. Locate the left taillight diverter and connect the red wire to it. Locate the "LEFT TURN/BRAKE" diverter and connect the black wire to it.

Step 5. Test the lube pump, diverter, and conductor cable installation before the installation of wiring harness on the motor home.

For Installation Testing (pg 17), Towing Checklist (pg 18), and Troubleshooting (pg 20) see the back section of the this Manual.

MOTOR HOME ELECTRICAL INSTALLATION:

For proper installation it is necessary for you to have available the following tools which are not provided in the kit:

• 12 volt DC continuity tester
• Small wire cutter, wire stripper, wire terminal crimper
• Electrical tape
• Screw driver
• Electric drill, #7 drill bit, and 3/8" nut driver bit

INSTALLATION OF ELECTRICAL MONITOR (REFERENCE PAGE 18 FOR SCHEMATIC)

NOTE: A quick-disconnect plug has been manufactured into the back of the Electrical Monitor. This allows for easy replacement of the unit should it become necessary. Simply unplug the harness from the back of the monitor.

Step 1. Select a suitable location for the Electronic Monitor on the dashboard of the motor home. The location should be suitable for the driver to both hear and see the monitor. Screws are provided for it's mounting (4 - #6 self tapping screws).

NOTE: **THE MONITOR IS A VITAL WARNING DEVICE TO PROTECT THE TRANSMISSION OF YOUR TOWED VEHICLE SHOULD SOMETHING GO WRONG WITH THE LUBE PUMP SYSTEM. IT IS VERY IMPORTANT THAT THE MONITOR BE MOUNTED IN A LOCATION THAT IS EASY TO SEE AND HEAR IN CASE IT ALARMS. IF IT ALARMS, STOP THE COACH IMMEDIATELY AND DETERMINE WHAT IS WRONG OR YOU WILL DAMAGE YOUR TRANSMISSION.**

Step 2. Turn the ignition key of the motor home to the **ON** position. Use a 12 volt DC continuity lamp tester to identify an appropriate accessory ignition terminal connection at the motor home engine fuse box. Switch the ignition key **OFF** and **ON** to make certain that the terminal is "**HOT**" only when the ignition key is turned **ON**. Be sure no other accessories will be sharing this connection.

Step 3. Cut the fused orange wire from the monitor to an appropriate length. Strip the end of the wire 1/4" and crimp a male tab terminal onto the wire. Connect the orange wire to the ignition terminal located in step 2.

- Step 4. Cut the white wire to an appropriate length, strip the end of the wire ¼”, crimp a seamed spade terminal onto the wire; attach the wire to a suitable ground as previously described.
- Step 5. Cut the heavy blue wire from the monitor to a suitable length, strip the wire ¼”, crimp a 3/8” ring terminal onto the wire. Connect the terminal to the Start battery or a battery solenoid only. **Do not** use fuse box or splice into a wire. (For 24-volt DC systems find a constant 12-volt DC source of power.)
- Step 6. The red and black wires of the monitor will be connected to the red and black wires of the 2-conductor cable, after the 45-ft. conductor cable of the motorhome wiring harness has been routed to the front of the motorhome.

- **INSTALLATION MOTOR HOME WIRE HARNESS ASSEMBLY**

NOTE 1: Some motor homes have separate turn signal and brake lights; identified by amber turn signals and red brake lights (a 4-wire taillight system). This type of system will require the use of an additional taillight converter that converts the 4-wire system to a 3-wire system (combined turn signals and brake lights). The (PL-100) converter is not supplied in the kit but is available through **REMCO** or your local supply center.

NOTE 2: If necessary, refer to the alternate motorhome wiring **DIAGRAM 7, below.**

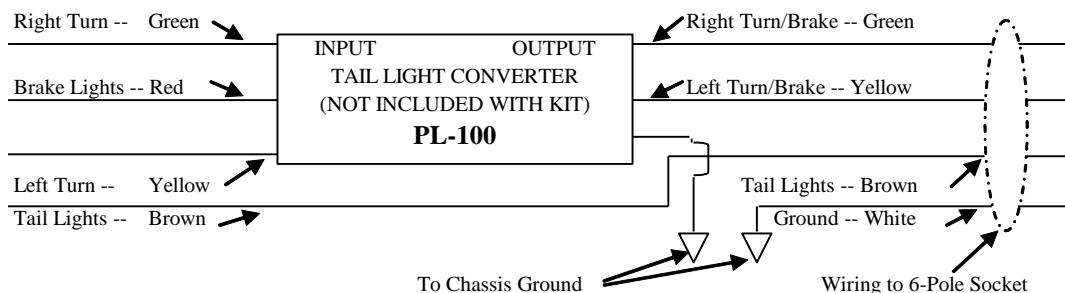

DIAGRAM 7
ALTERNATE MOTORHOME WIRING

NOTE 3: Carefully review the electrical schematic diagram on **Page 18** to assure understanding of the circuitry.

NOTE 4: As in the installation of the socket on the towed vehicle, be aware of exposure of the socket to road damage. The coiled cable should rest on the tow bar if the sockets on both vehicles are either opposite each other or the sockets are mounted in the middle of both vehicles to allow the cable to rest on the tow bar. Whichever way is used, the result will be the same – to keep the cable from dragging on the ground.

NOTE 5: Use normal precautions with all wiring in the motorhome to avoid sharp edges, moving parts, and surfaces that become very hot from the vehicle being driven.

Step 1. Begin the installation by mounting the 6-conductor socket on or near the center of the rear bumper (next to the towing ball) using the socket bracket and 1/4" x 3/4" self-tapping metal screws provided.

NOTE 6: Use a number 7 drill bit to drill the holes for the self-tapping screws.

Step 2. Strip the end of the white wire extending from the socket 1/4" and crimp on a seamed spade terminal. Ground the white wire to a suitable nearby bolt or screw, or drill a hole in an adjacent metal surface and use one of the 1/4" x 3/4" self-tapping metal screws. Please don't ground to any painted metal surface!

Step 3. Find the motor home taillight tow harness wires at the back of the motorhome underneath the bumper.

Step 4. Have an assistant turn **ON** the taillights.

Step 5. Connect the continuity tester to a ground.

Step 6. Probe each wire for a "HOT" wire. Have an assistant turn OFF and ON the taillight switch to verify the correct wire. Label the wire "TAILLIGHTS". Turn OFF the taillights.

Step 7. Have an assistant turn ON the left turn signal.

Step 8. Probe each wire for a "HOT" wire, watch for the tester to blink with turn signal to verify the correct wire. Label the wire "LEFT TURN". Follow the same procedure for right turn signal and label the wire "RIGHT TURN".

Step 9. If the motor home has separate turn signal and brake lights, have the assistant depress the brake pedal, probe each of the remaining wires for a "HOT" wire. Label the wire "BRAKES".

Step 10. Use a wire tap connector provided in the kit to attach the brown conductor wire onto the wire labeled "TAILLIGHTS".

Step 11. Use a wire tap connector to attach the yellow conductor wire onto the wire labeled "LEFT TURN".

Step 12. Use a wire tap connector to attach the green conductor to the wire labeled "RIGHT TURN".

Step 13. Route the 45-ft. 2-conductor cable (black/red) under the motorhome (preferably along the driver side frame rail) from the socket to the front of the motorhome. Follow existing wires or other protected routes. Keep cable clear of parts, which are moving or become hot. Securely attach the cable under the motor home to prevent damage from road hazards. The use of wire loom to protect wires is preferred over exposing wires to elements.

Step 14. Using 2 of the butt connectors (provided) connect the red and black wires of the monitor to the red and black wires of the 2-conductor cable.

ELECTRICAL SCHEMATIC - MOTORHOME

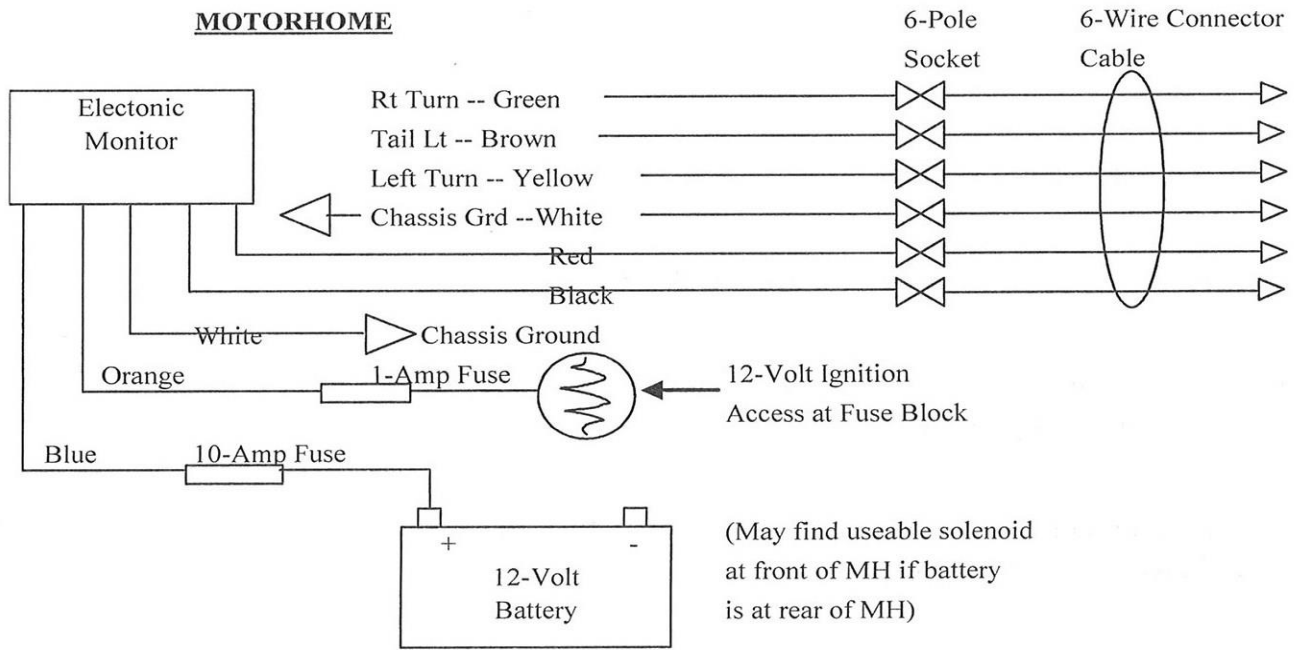

SOCKET & PLUG - DETAIL

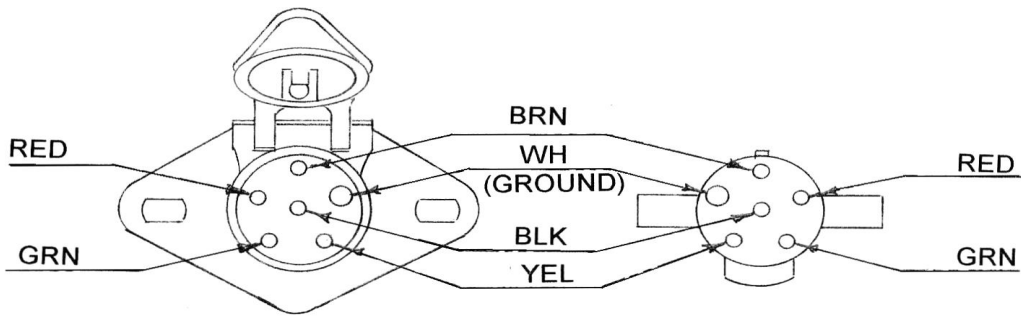

MOTORHOME & CAR SOCKETS
(Same on both vehicles)

CONNECTOR CABLE PLUGS
(Same on both ends)

TESTING THE INSTALLATION

- Step 1. To test the wiring just completed, first turn **ON** the ignition switch in the motor home. If the monitor switch is in the **OFF** position, the monitor will remain mute. Turn the monitor switch **ON** and an alarm tone will sound and the red light will illuminate. When driving the motor home by itself (not towing), the monitor should be in the **OFF** position.
- Step 2. Test the wiring completed in the towed vehicle to the rear socket of the motor home using the coiled cable provided. If the plug feels loose in the socket, the pins in the socket can be spread with a slotted screwdriver so contact is tight.
- Step 3. Turn **ON** the ignition switch in the motor home. If the monitor switch is in the **OFF** position, the alarm tone and the red light will come on and remain on until the monitor switch is turned on. Turn the monitor switch **ON**. The alarm tone and red light should go **OFF** in 10-30 seconds as soon as the pump builds up pressure in the transmission of the towed vehicle. At this point when the alarm tone and red light go **OFF**, the green light should illuminate if the system is functioning correctly. If the alarm tone and red light remain **ON** after 30 seconds, this indicates the pump is not running or there is a wiring error. Recheck the circuitry to make certain all wires are connected properly.
- Step 4. Turn **ON** the taillights and left and right turn signals to confirm that each respective light glows on the towed vehicle.
- Step 5. This completes the installation and testing of the Motor Coach Side of Lube Pump System.

NOTE: WHEN INSTALLATION HAS BEEN COMPLETED, THE INSTALLER NEEDS TO RETURN THE INSTALLATION INSTRUCTION BOOKLET TO THE END CUSTOMER. ALSO, THE WARRANTY CARD INCLUDED IN THE BOOKLET NEEDS TO BE COMPLETED AND RETURNED TO REMCO INDUSTRIES.

TOWING CHECKLIST:

Make sure the tow bar, ball coupler and safety chains are all secured.

1. Make sure the ends of the coiled connector cable are securely plugged into the motorhome socket and the towed car socket with the weight of the cable being supported by the tow bar. The pins in the sockets can be spread to make better contact. You can wrap the coiled cable around the towbar to keep the cable secure while towing.
2. Turn the ignition switch of the towed vehicle to the “**UNLOCKED**” position to release the steering wheel lock, if your vehicle has this feature.
3. Shift the transmission of the towed vehicle to neutral, “N,” and release the parking brake. Turn the ignition switch back as far as you can. The key is now in the correct position for towing. As long as the transmission is in “N,” the key cannot go into the locked position. This will allow the front wheels to track behind the motorhome while towing and allow no electricity to be drained from the battery. The only exceptions are in the NOTE below.
4. Lock the doors of the towed vehicle to prevent children or unauthorized persons from operating the controls. This may require having a second key.
5. Connect your towed vehicle and start the motor home engine. The “Green Light” indicates you are ready to travel. **Do not** tow unless the Green Light is illuminated.

NOTE: MANY CHRYSLER, GM, FORD, AND TOYOTA VEHICLES MAY HAVE TO GO THRU THIS PROCEDURE: To tow and unlock the steering wheel on your vehicle, you must put the ignition switch in the first position on the steering column. When you do this, the odometer and transmission indicator will light up on the dashboard and could drain the power from your battery while towing. To keep the battery from draining, open the hood and open the fuse box and find the “memory” or “hazard” switch/fuse. Then pull the switch/fuse out approx. ¼” to disable the lights on the dashboard. After you have finished towing, simply open the hood, open the fuse box, and push in the memory switch. Everything will be back to normal, with the exception that the radio clock and stations will need to be reset.

HAPPY MOTORING!

TROUBLE-SHOOTING TIPS

CONDITIONS:

- With the RV engine “ON”
- With the monitor switch “ON”
- Towed vehicle connected to the motor home via the coiled cable

PROBLEM: Red light/alarm comes on and Pump is not running

1. Check the 10-amp fuse in the blue wire at the fuse holder in the blue wire.
2. Check the connection of the blue wire at the motor home battery.
3. Check for tight connections of the coiled cable at both motor home and towed vehicle sockets.
4. Check with a continuity tester for power on the red wire at the socket of the motor home. Continue with the socket on the front of the towed vehicle. There should be 12 – 14 volts getting to the pump.
5. Call **REMCO** for more information.

PROBLEM: Red light/alarm comes on and Pump is running

1. Check transmission fluid level in towed vehicle. See vehicle manual.
2. Check for damage of the socket wiring and lube pump hoses from road hazards.
3. Use a test light to check power across both terminals of the pressure sensor at the selector valve. If one has a 12 Volt DC Voltage Meter, then measured voltage should be the same on both terminals, 12 – 14 volts. Trace the black wire to the monitor. There should be at least 12 volts at the back of the monitor on both Red and Black wires.
4. Check the flow of the transmission fluid from the pump. The lube pump should pump a quart of fluid in about 10 to 12 seconds. Check amperage on pump with an AMP meter. With pump getting at least 12 volts of electricity it should be pulling between 2.0-3.5 Amps. Anything above or below that threshold means pump is going bad.
5. Check for grounding/shorting of the red wire of the 2-conductor cable running back from the monitor to the socket of the motor home.
6. Call **REMCO** for information.

CONDITIONS:

RV “ON”, with towed vehicle connected

PROBLEM: All monitor lights are OFF (red and green)

1. With the engine switch “ON”, check the fuse in the orange wire at the 1 AMP fuse holder in the orange wire.
2. Check connection to ignition accessory terminal. See INSTALLATION OF ELECTRONIC MONITOR, Step 2.
3. Check the white ground connection from the monitor.
4. If the above checks are OK, call **REMCO Industries**.

INSTALLATION OF TALLIGHT DIVERTERS FOR A 3 WIRE SYSTEM

NOTE: This system will use 3 of the 4 diverters provided in the kit. The preferred location for the solid-state diverters is as close to the taillight assembly kit as possible.

Step 1. Access the wires for the taillight assembly (usually through the trunk in a sedan and wagon).

Step 2. Turn **ON** the taillights.

Step 3. Ground the continuity tester to a suitable ground.

Step 4. Probe each wire to locate a “HOT” wire. Turn **OFF** and **ON** the taillight switch to verify the correct wire. Label the wire “TAILLIGHTS”. Turn **OFF** the taillights.

Step 5. Turn **ON** the left turn signal. Probe each wire for a “HOT” wire. Watch for the continuity tester to blink with the turn signal to verify the correct wire. Label the wire “LEFT TURN”. Follow the same procedure for the right turn signal, but label the wire “RIGHT TURN”.

Note: Refer to **DIAGRAM , page 25** for the steps listed below.

Step 6. Turn **ON** the taillights. Locate the wire labeled “TAILLIGHTS”. Cut the wire and confirm that the taillights have gone **OUT**. Turn **OFF** the taillights.

Step 7. Strip each wire ¼”. Crimp a ¼” female terminal onto each wire.

Step 8. Connect the wire that goes to the taillight bulb to the “OUT” of the diverter, connect the remaining wire to either “IN” terminal of the diverter.

Step 9. Turn **ON** the left turn signal. Locate the wire labeled “LEFT TURN”. Cut the wire and confirm that the turn signal light has gone **OUT**.

Step 10. Strip each wire ¼”. Crimp a ¼” female terminal onto each wire.

Step 11. Connect the wire that goes to the turn signal bulb to the “OUT” terminal of the diverter, connect the remaining wire to either “IN” terminal of the diverter. Locate the wire labeled “RIGHT TURN” and follow the same procedure.

INSTALLATION OF CONDUCTOR CABLE FOR 3-WIRE SYSTEMS

NOTE: Refer to **DIAGRAM , page 25** for the steps listed below.

- Step 1. Route the conductor cable from the socket to the diverters.
- Step 2. Separate the towed vehicle's conductor cable sufficiently to attach to the diverters.
- Step 3. Strip each wire $\frac{1}{4}$ ". Crimp a $\frac{1}{4}$ " female terminal onto the yellow, green, and brown conductor wire.
- Step 4. Locate the "TAILLIGHT" diverter. Connect the brown conductor wire to the remaining "IN" terminal of the diverter.
- Step 5. Locate the "LEFT TURN" diverter. Connect the yellow conductor wire to the remaining "IN" terminal of the diverter.
- Step 6. Locate the "RIGHT TURN" diverter. Connect the green conductor wire to the remaining "IN" terminal of the diverter.

**At this point return to pg 15
for the
Motorhome Electrical Instructions**

TOWED VEHICLE
3 Wire Schematic

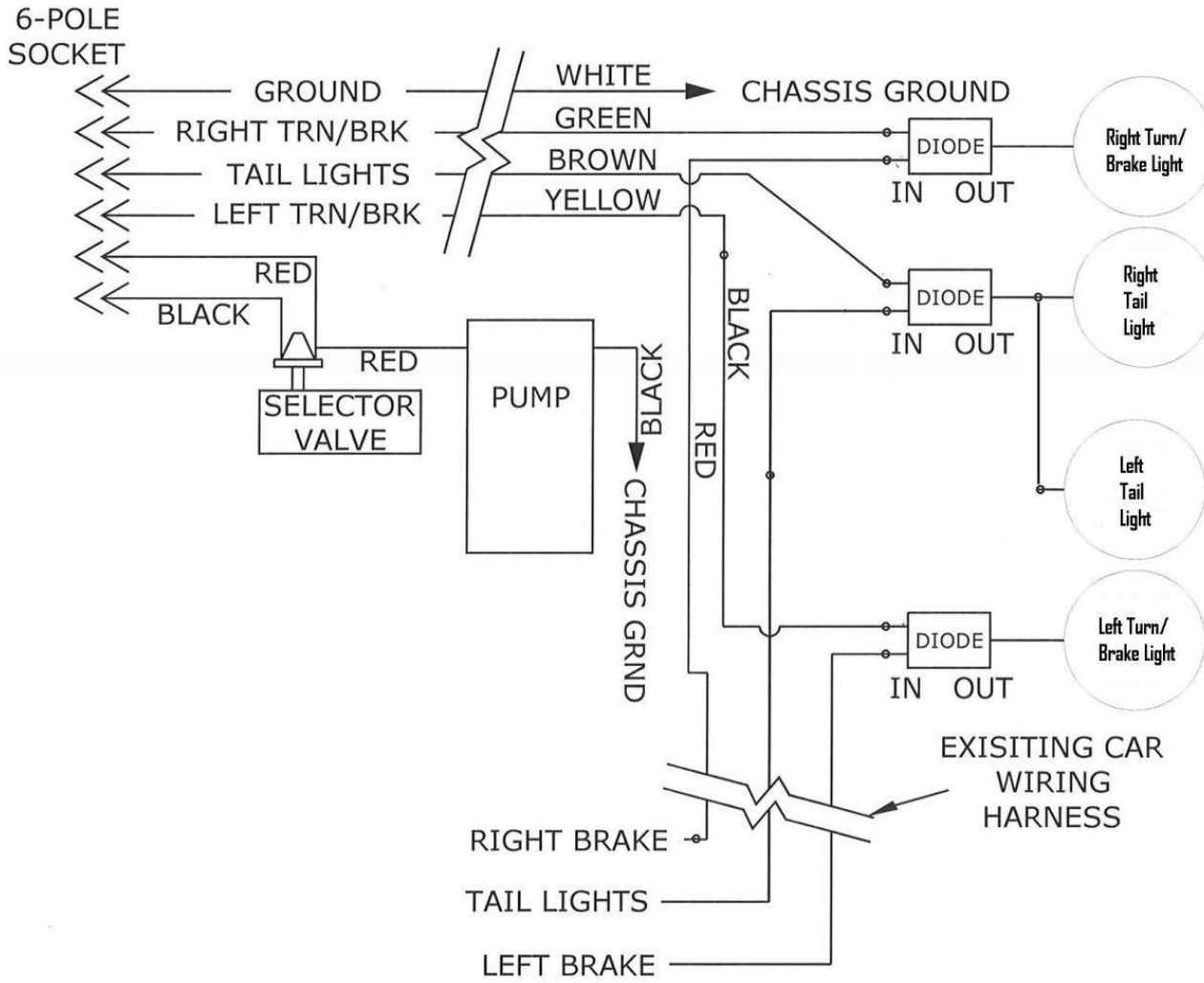

REMCO HAS THESE PRODUCTS FOR YOUR TOWING CONVENIENCE

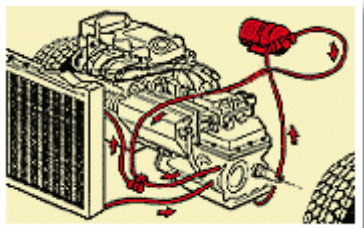

REMCO'S Lube-Pump lubricates and cools the Front Wheel Drive, Select rear Wheel Drive, Four-Wheel Drive, and All Wheel Drive vehicles while towing.



REMCO'S Tail Light Wiring Kit is for easy hook up of your tail lights and turn signals for towing.



REMCO'S 12 Volt (DC) RV Water System Pumps

REMCO
The Towing Experts

4605 County Road 82 SE
Alexandria, MN 56308
1-800-228-2481
763-253-4743
Fax: 763-253-4741